



# HOW THE GUN WORKS

## CALIBER .50, M2 BROWNING MACHINE GUN

THIS PAMPHLET IS  
IDENTIFIED AS  
FGC

*Prepared by-*

**AC SPARK PLUG DIVISION, General Motors Corporation  
FLINT, MICHIGAN, U.S.A.**

**FRIGIDAIRE DIVISION, General Motors Corporation  
DAYTON, OHIO, U.S.A.**

### BROWNING MACHINE GUNS, CALIBER .50, M2



Aircraft (air-cooled)..... weight 61 lbs.

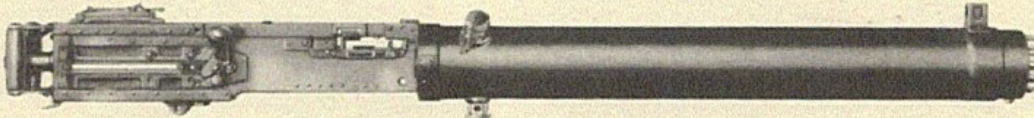

Anti-aircraft (water-cooled)..... weight 121.5 lbs.



Tank and Field (air-cooled)..... weight 81 lbs.

## INTRODUCTION

The Browning Machine Gun, caliber .50, is a highly efficient automatic weapon built to precision standards. It is produced with three types of barrels for various applications as shown to the left. The working parts, however, which automatically perform the numerous mechanical operations while the gun is firing, are the same in all three models. The following pages describe and illustrate "HOW THE GUN WORKS."

1

Each time a cartridge is fired, the mechanical action within the gun involves many moving parts. To gain a knowledge of the operation of these parts and their relationship to each other, the action has been separated into various phases. These are described in the following order:

1. FIRING
2. RECOILING
3. COUNTER-RECOILING
4. COCKING
5. AUTOMATIC FIRING
6. FEEDING
7. EXTRACTING AND EJECTING

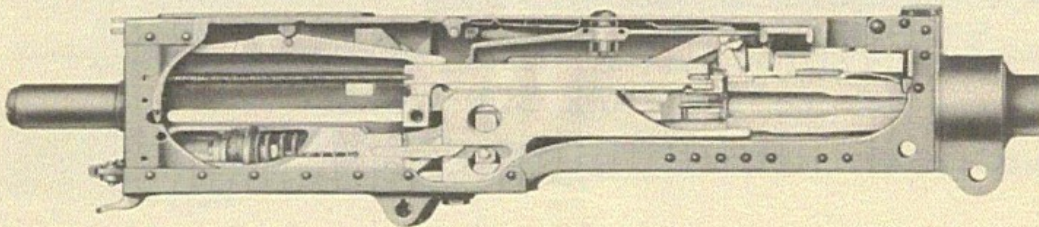

2

## FIRING

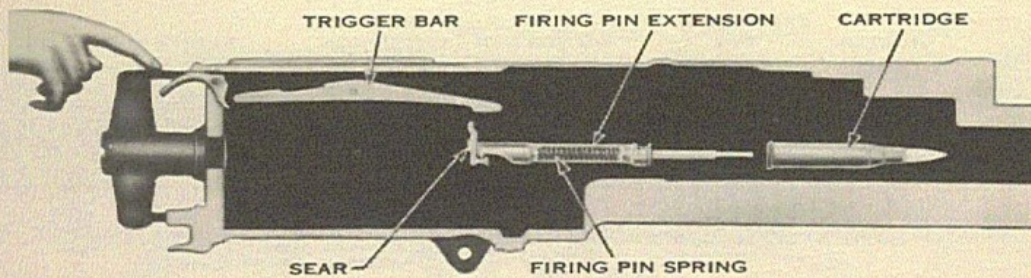

When the gun has been loaded and the firing pin spring has been cocked or compressed by hand, the firing mechanism is as shown. The gun is now ready to fire.

In this case a manual trigger and trigger bar are shown for firing, although for some applications the gun is fired by mechanical or electrical accessories.

3

## FIRING

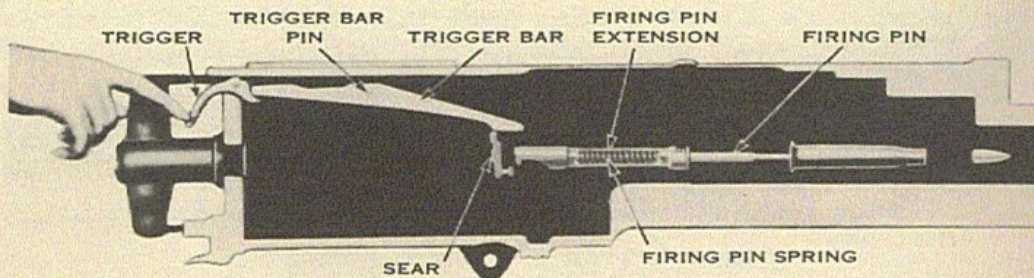

When the trigger is pressed it raises the back end of the trigger bar. The trigger bar pivots on the trigger bar pin, causing the front end to press down on the top of the sear. The sear is forced down until the notch in the sear is disengaged from the shoulder of the firing pin extension. The firing pin and firing pin extension are driven forward by the firing pin spring to fire the cartridge.

4

## RECOILING

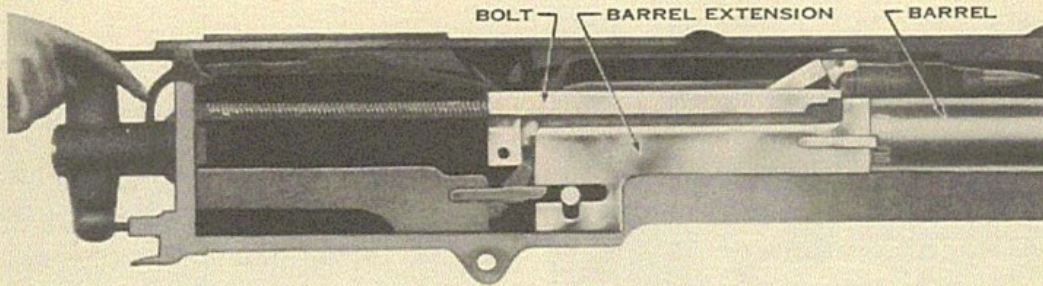

The complete cycle of the recoiling portion of the gun, which takes place as each cartridge is fired, consists of the recoil stroke when certain parts of the gun move rearward and the counter-recoil stroke when these same parts move forward. At the instant of firing, the barrel, barrel extension, and bolt, known as the recoiling portion, are in the forward position in the gun.

5

## RECOILING

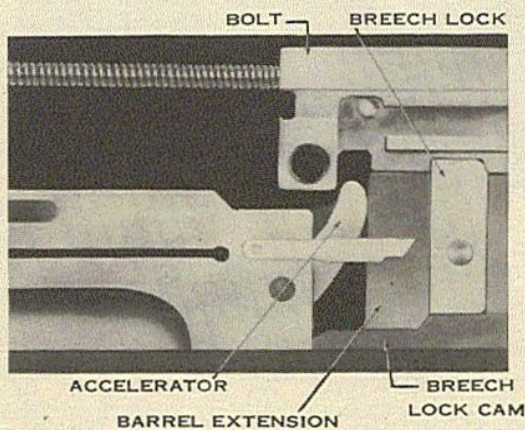

At this time the bolt is held securely against the base of the cartridge by the breech lock, which extends up from the barrel extension into a notch in the underside of the bolt.

6

## RECOILING

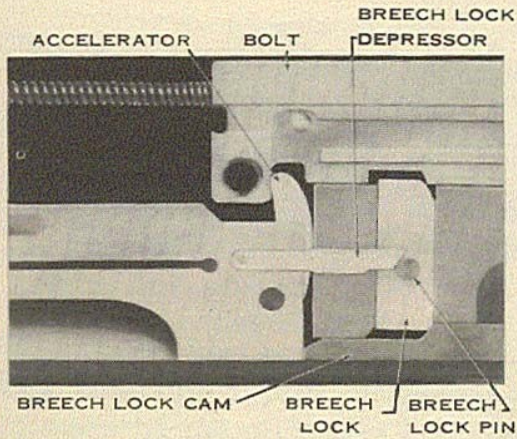

After the cartridge explodes and as the bullet travels out of the barrel, the force of recoil drives the recoiling portion rearward. During the first three-quarters inch of travel the breech lock is pushed back off the breech lock cam step. This permits the breech lock to be forced down out of the notch in the bolt by the breech lock depressors engaging the breech lock pin. This unlocks the bolt.

7

## RECOILING

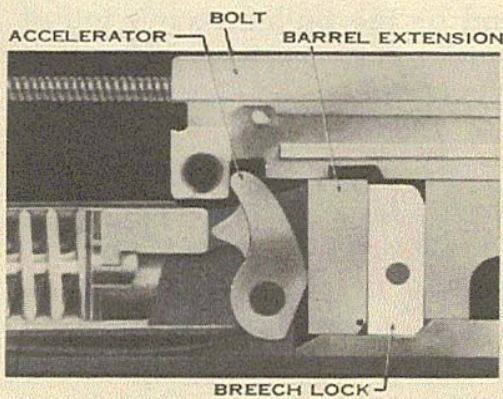

As the recoiling portion moves toward the rear the barrel extension rolls the accelerator rearward. The tip of the accelerator strikes the lower projection on the bolt and hastens or accelerates the bolt to the rear. (Note breech lock completely disengaged from bolt notch.)

8

## RECOILING

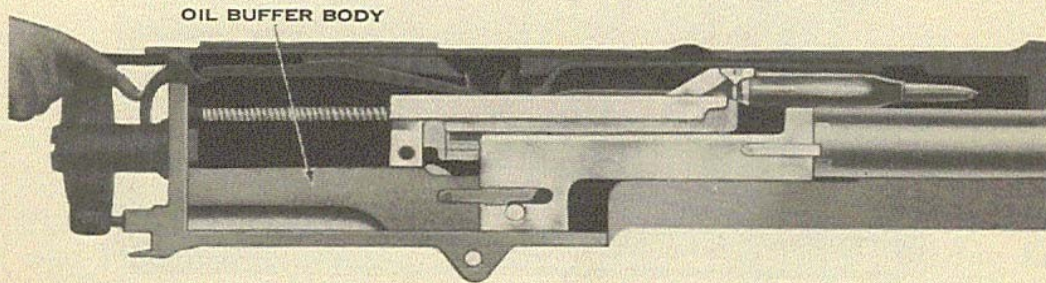

The barrel and barrel extension have a total rearward travel of one and one-eighth inches at which time they are completely stopped by the oil buffer body assembly.

9

## RECOILING

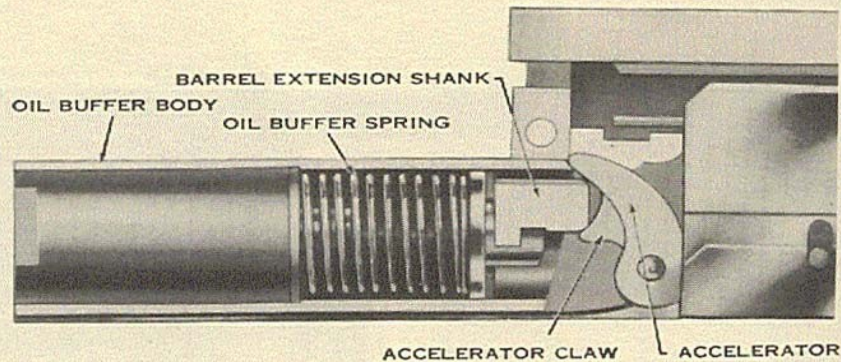

During this recoil of one and one-eighth inches the oil buffer spring is compressed in the oil buffer body by the barrel extension shank. The spring is locked in the compressed position by the claws of the accelerator which are moved against the shoulders of the barrel extension shank.

10

## RECOILING

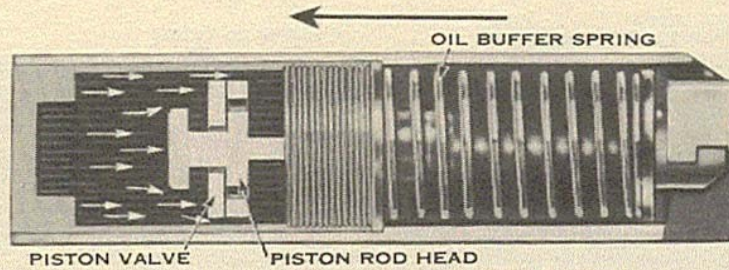

The oil buffer assists the oil buffer spring in bringing the barrel and barrel extension to rest during the recoil stroke. During the one and one-eighth inch of rearward travel the piston rod head is forced from the forward end of the oil buffer tube to the rear. The oil at the rear of the oil buffer tube under pressure of the piston escapes to the front side of the piston. Its only path is through restricted notches between the edge of the piston rod head and the oil buffer tube.

11

## RECOILING

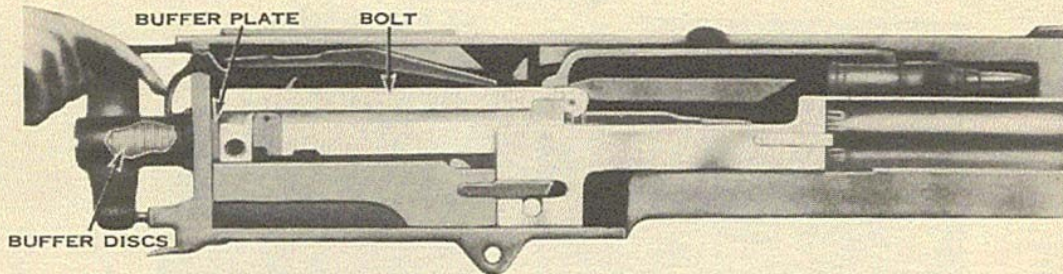

The bolt travels rearward for a total of seven and one-eighth inches. During this travel the two, nested driving springs are compressed. The rearward stroke of the bolt is finally stopped as the bolt strikes the buffer plate. Thus, part of the recoil energy of the bolt is stored in the driving springs and the remainder is absorbed by the buffer discs in the back plate.

12

## COUNTER-RECOILING

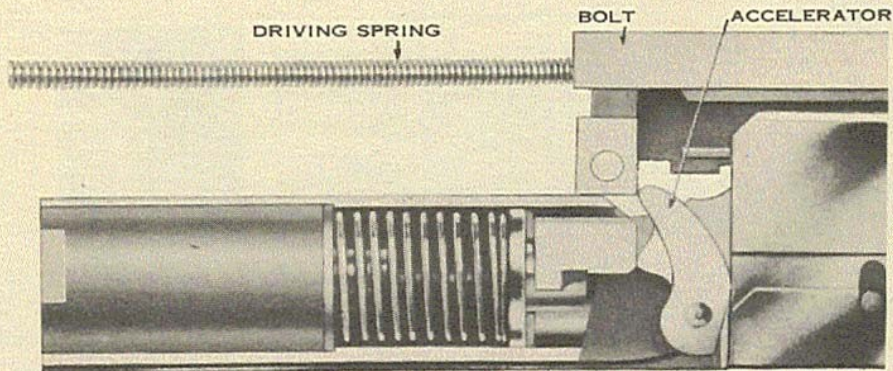

After completion of the recoil stroke the bolt is forced forward by the energy stored in the driving spring and the compressed buffer discs. When the bolt has moved forward about five inches the tip of the accelerator is struck by a projection on the bottom of the bolt. This rolls the accelerator forward.

13

## COUNTER-RECOILING

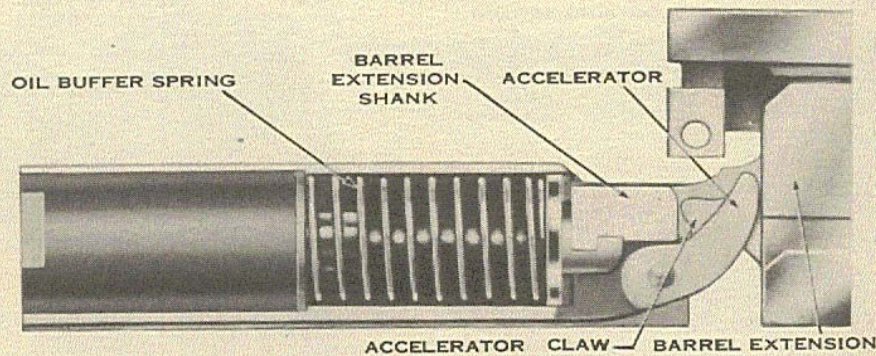

As the accelerator rolls forward the accelerator claws are moved away from the shoulders of the barrel extension shank. This releases the oil buffer spring. The energy stored in the spring shoves the barrel extension and barrel forward.

14



## COUNTER-RECOILING

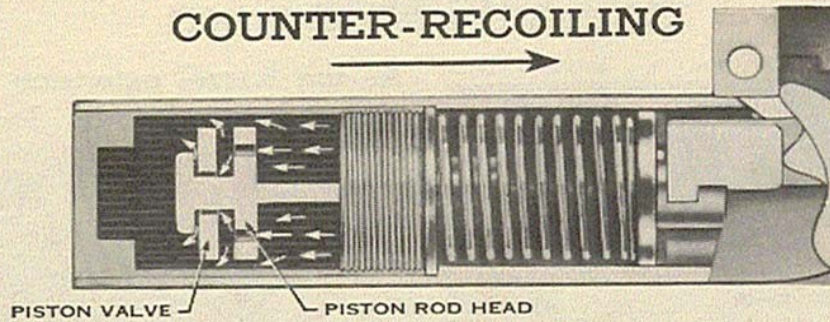

No restriction to motion is desired on the forward or counter-recoil stroke of the barrel and barrel extension; therefore, on the forward stroke additional openings for oil flow are provided in the piston rod head of the oil buffer assembly. The piston valve is forced away from the piston rod head as the parts move forward, uncovering these additional openings. This provides an additional path and permits oil to escape freely at the opening in the center of the piston valve as well as at the edge of the piston valve next to the tube wall.

15

## COUNTER-RECOILING

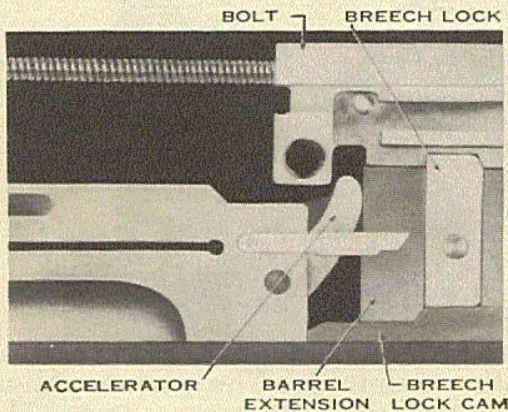

As the barrel extension moves forward the breech lock engages the breech lock cam and is forced upward. The bolt, which has been continuing its forward motion since striking the accelerator, has at this instant reached a position where the notch on the underside is directly above the breech lock, thus permitting the breech lock to engage the bolt. The bolt is thereby locked to the breech end of the barrel just before the recoiling portion reaches the firing position.

16

## COCKING

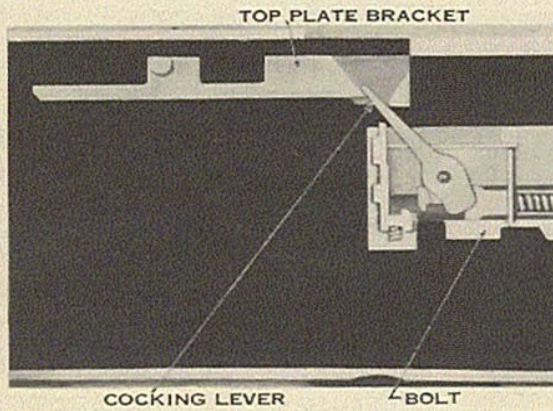

The act of cocking the gun is begun as the bolt starts to recoil immediately after firing. Thus the tip of the cocking lever, which is in the V-slot in the top plate bracket, is forced forward.

17

## COCKING

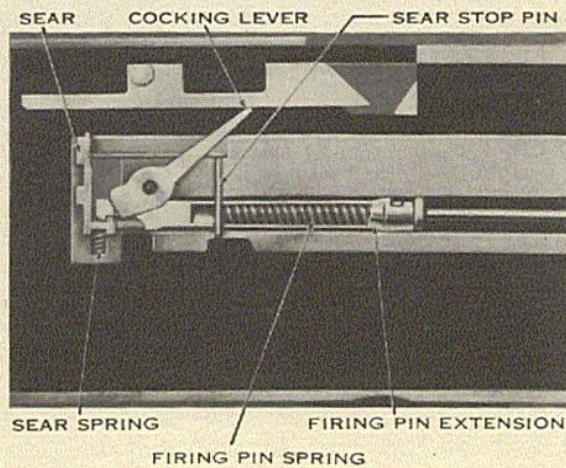

The cocking lever is pivoted so that the lower end forces the firing pin extension rearward. The firing pin spring is thus compressed against the sear stop pin. The shoulder at the back end of the firing pin extension is hooked over the notch at the bottom of the sear under pressure of the sear spring.

18

## COCKING

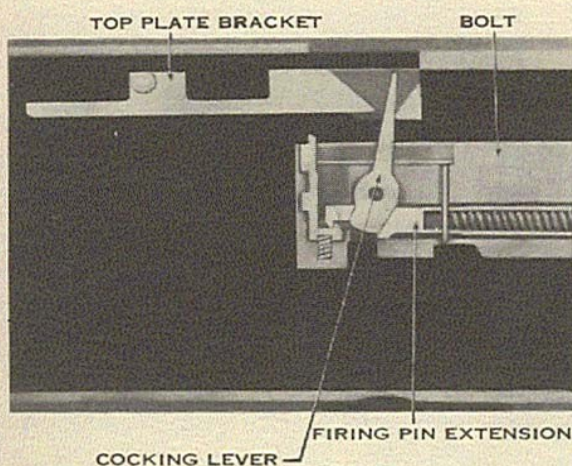

During the forward motion of the bolt the tip of the cocking lever enters the V-slot of the top plate bracket. This action swings the bottom of the cocking lever out of the path of the firing pin extension; thus permitting the firing pin to snap forward to fire the cartridge.

19

## COCKING

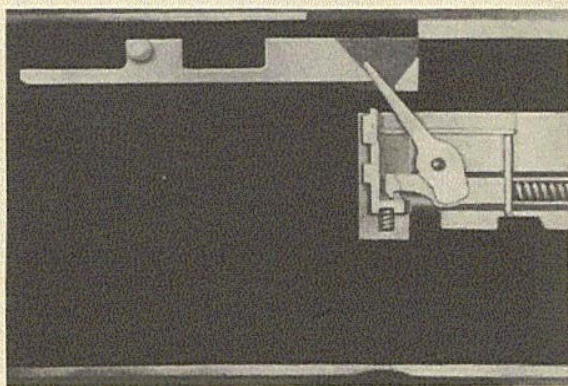

When the recoiling portion is almost in the forward position the gun is ready to fire. If no trigger action is given at this instant, the recoiling portion assumes its final forward position and the gun ceases to fire. The parts are now in the position shown on page 3 and the gun is again ready to fire.

20

## AUTOMATIC FIRING

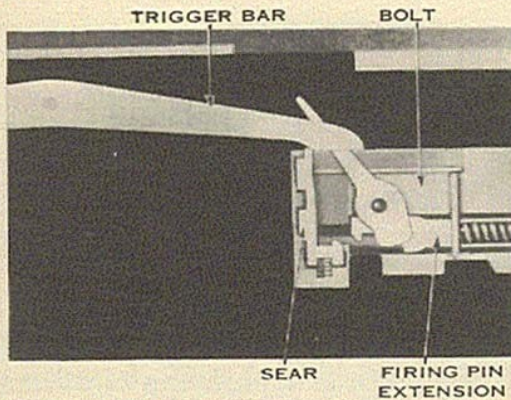

For automatic firing the trigger is pressed and held down. The sear is depressed as its tip is carried against the cam surface of the trigger bar by the forward movement of the bolt near the end of the counter-recoil stroke. The notch in the bottom of the sear releases the firing pin extension and the firing pin, thus

automatically firing the next cartridge at the completion of the forward stroke. The gun fires automatically as long as trigger action is maintained and until the ammunition supply is exhausted.

21

## FEEDING

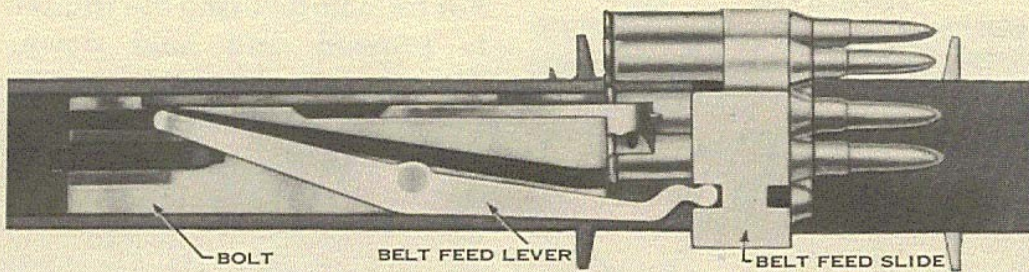

The belt feed mechanism is actuated by the bolt. When the bolt is in the forward position the belt feed slide is within the confines of the gun. This illustration shows the mechanism as from above with the cover removed. A stud at the rear of the belt feed lever is engaged in the diagonal groove or way in the top of the bolt.

22

## FEEDING

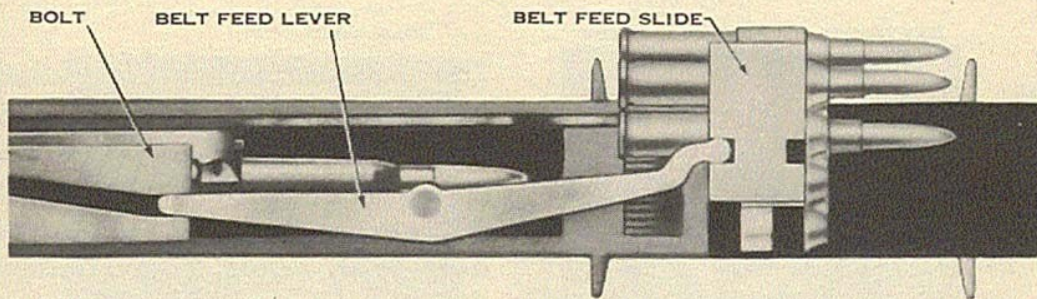

As the bolt moves rearward during recoil the belt feed lever is pivoted. The forward end of the belt feed lever moves the belt feed slide out of the side of the gun and over the ammunition belt. Ammunition feed shown is from the left side of the gun. Feed from either side is possible with all caliber .50, M2 guns. (Note: On previous models, namely the M1921 and M1921A, ammunition could be fed from only the left side.)

23

## FEEDING

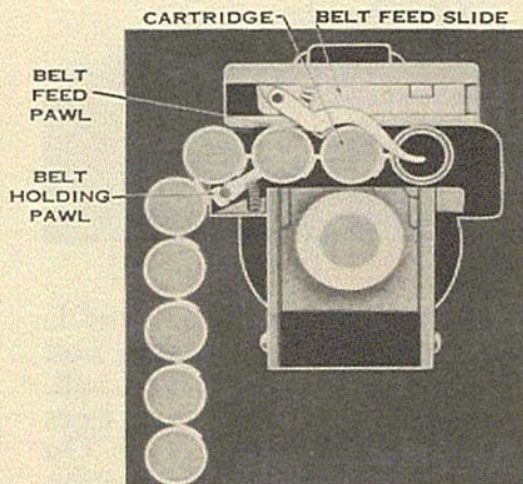

The ammunition belt is pulled into the gun by the belt feed pawl which is attached to the belt feed slide. When the bolt is forward the belt feed pawl has positioned a cartridge directly above the chamber. The belt holding pawl is in a raised position to prevent the ammunition belt from falling out of the gun.

24

## FEEDING

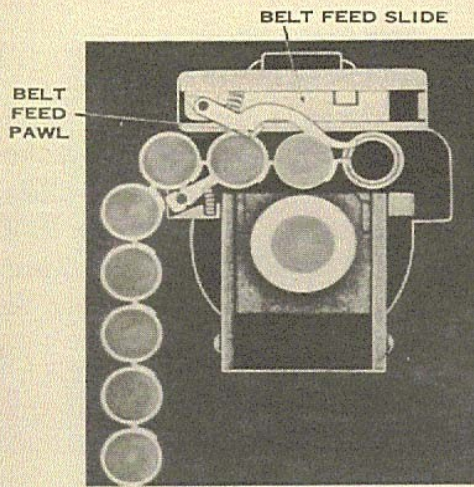

As the bolt recoils the belt feed slide is moved out over the belt, and the belt feed pawl pivots so as to ride over the next cartridge.

25

## FEEDING

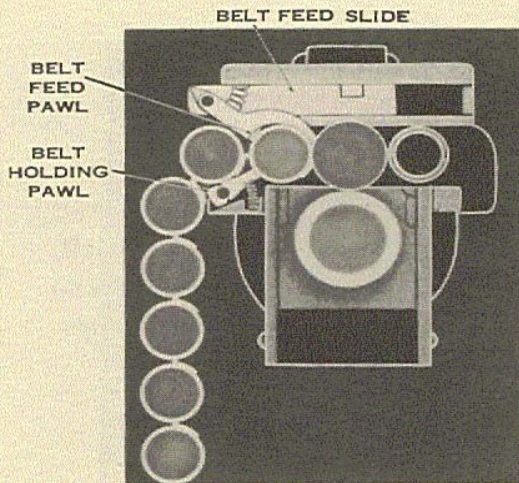

At the end of the recoil stroke the travel of the belt feed slide is sufficient to permit the belt feed pawl to snap down behind the next cartridge in order to pull the belt into the gun.

26

## FEEDING

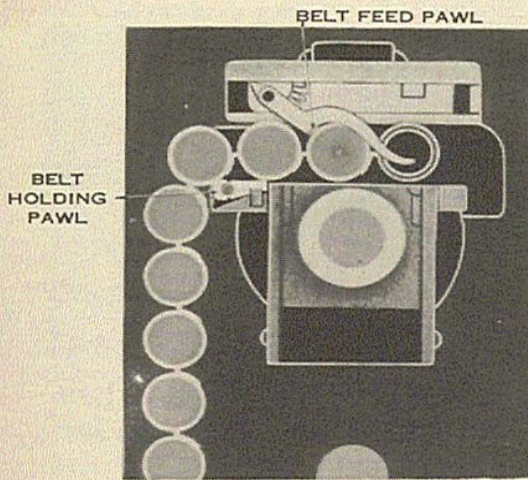

As the bolt moves forward on the counter-recoil stroke the belt is pulled into the gun by the belt feed pawl. The belt holding pawl is forced downward as a cartridge is pulled over it. When the forward stroke of the bolt is completed the belt holding pawl snaps up behind the next cartridge, as shown on page 24.

27

## EXTRACTING AND EJECTING

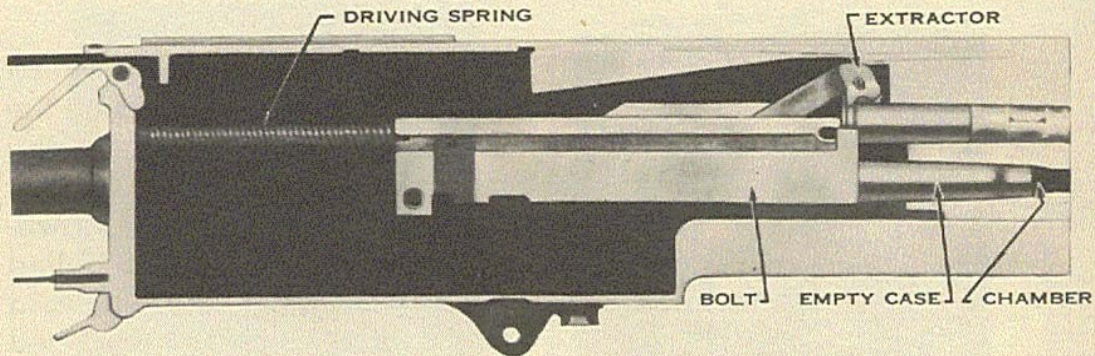

As recoil starts, a cartridge is drawn from the ammunition belt by the extractor. The empty case is withdrawn from the chamber by the T-slot in the front face of the bolt.

28

## EXTRACTING AND EJECTING

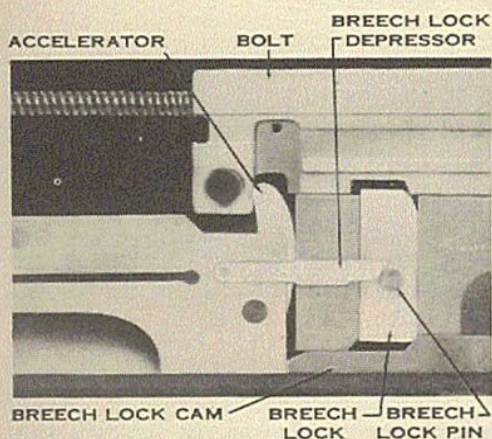

The empty case having been expanded by the force of explosion fits the chamber very snugly and the possibility exists of tearing the case if the withdrawal is too rapid. To prevent this and to insure slow initial withdrawal, the top front edge of the breech lock and front side of the notch in the bolt are beveled. Thus, as the breech lock is disengaged, the bolt moves away from the barrel and barrel extension in a gradual manner.

29

## EXTRACTING AND EJECTING

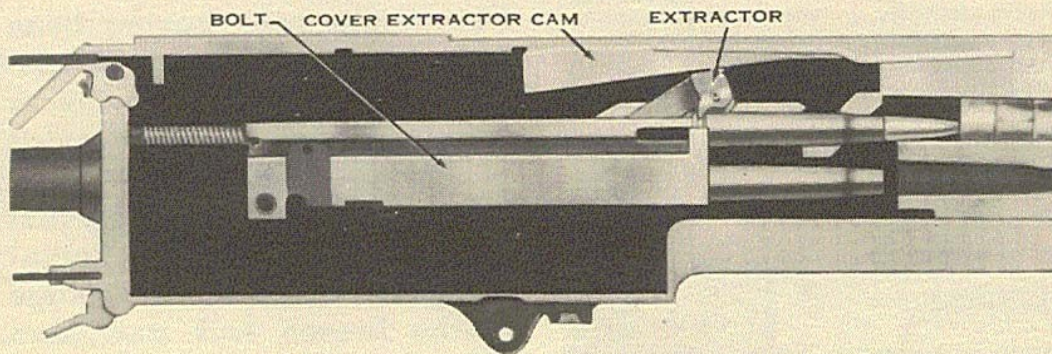

As the bolt moves to the rear the cover extractor cam forces the extractor down, causing the cartridge to enter the T-slot in the bolt.

30



## EXTRACTING AND EJECTING

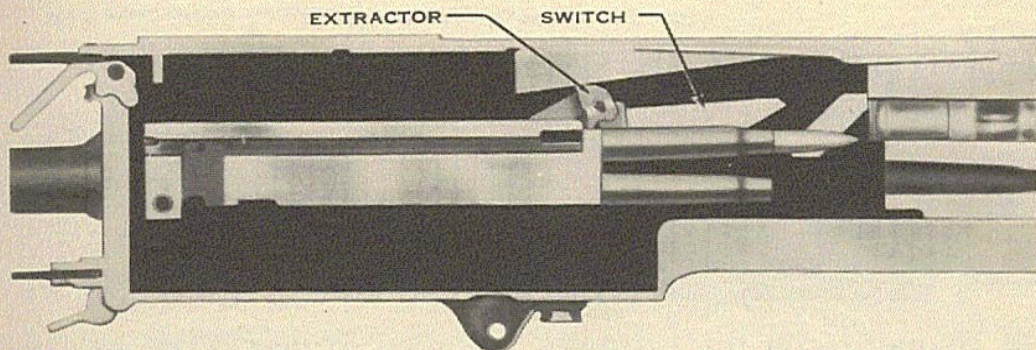

As the extractor is forced down a lug on the side of the extractor rides against the top of the switch causing the switch to pivot downward at the rear. Near the end of the rearward movement of the bolt the lug on the extractor overrides the end of the switch, and the switch snaps up to its normal position.

31

## EXTRACTING AND EJECTING

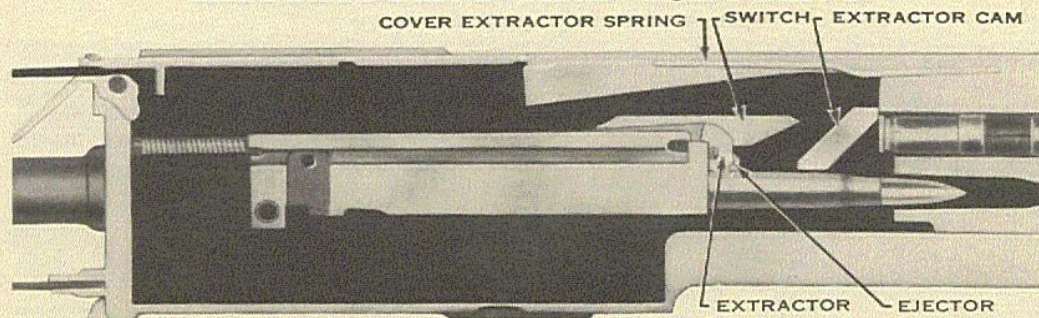

On counter-recoil the extractor is forced farther down by the extractor lug riding under the switch. The cartridge expels the empty case. The extractor stop pin in the bolt limits the travel of the extractor so that the cartridge, assisted by the ejector, enters the chamber. When the cartridge is nearly chambered the extractor rides up the extractor cam, compresses the cover extractor spring, and snaps into the groove in the next cartridge.

32

## ADDITIONAL COPIES

Additional copies of this pamphlet, FGC, may be had in limited numbers by writing War Products Service Training Department, Frigidaire Division, General Motors Corporation, Dayton, Ohio.

---

This booklet has been prepared by the AC Spark Plug Division and the Frigidaire Division of General Motors Corporation for the use of the Ordnance Department and all members of the United States armed forces who use, or are charged with the care of, the Caliber .50, Browning Machine Gun.

Robert M. Johnson  
0700014